

REVISIONS				
ZONE	REV.	DESCRIPTION	DATE	APPROVED

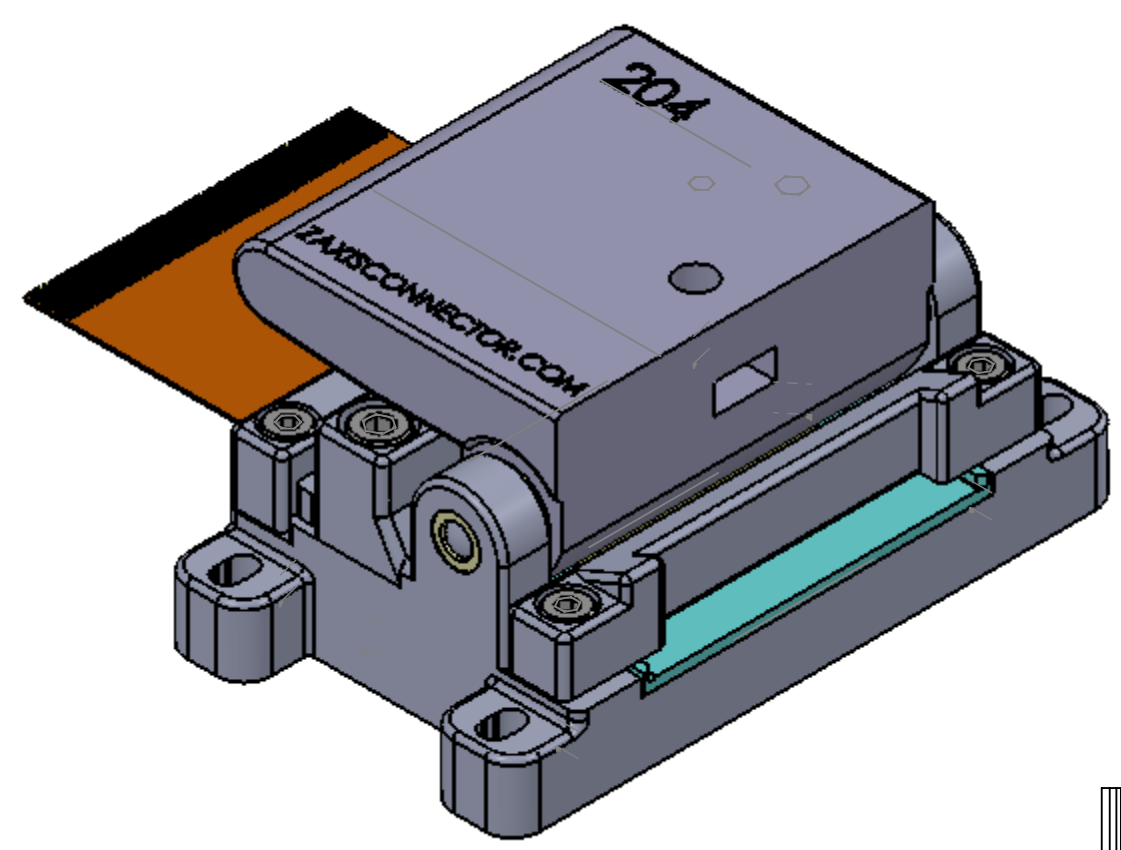

MAXIMUM FLEX WIDTH IS
.5mm X 60 TRACES.

[8.08]
.32 HEIGHT FROM
BOTTOM OF TEST FLEX
TO BOTTOM OF UNIT

4X CLEARANCE FOR
M2 OR 2-56 SHCS

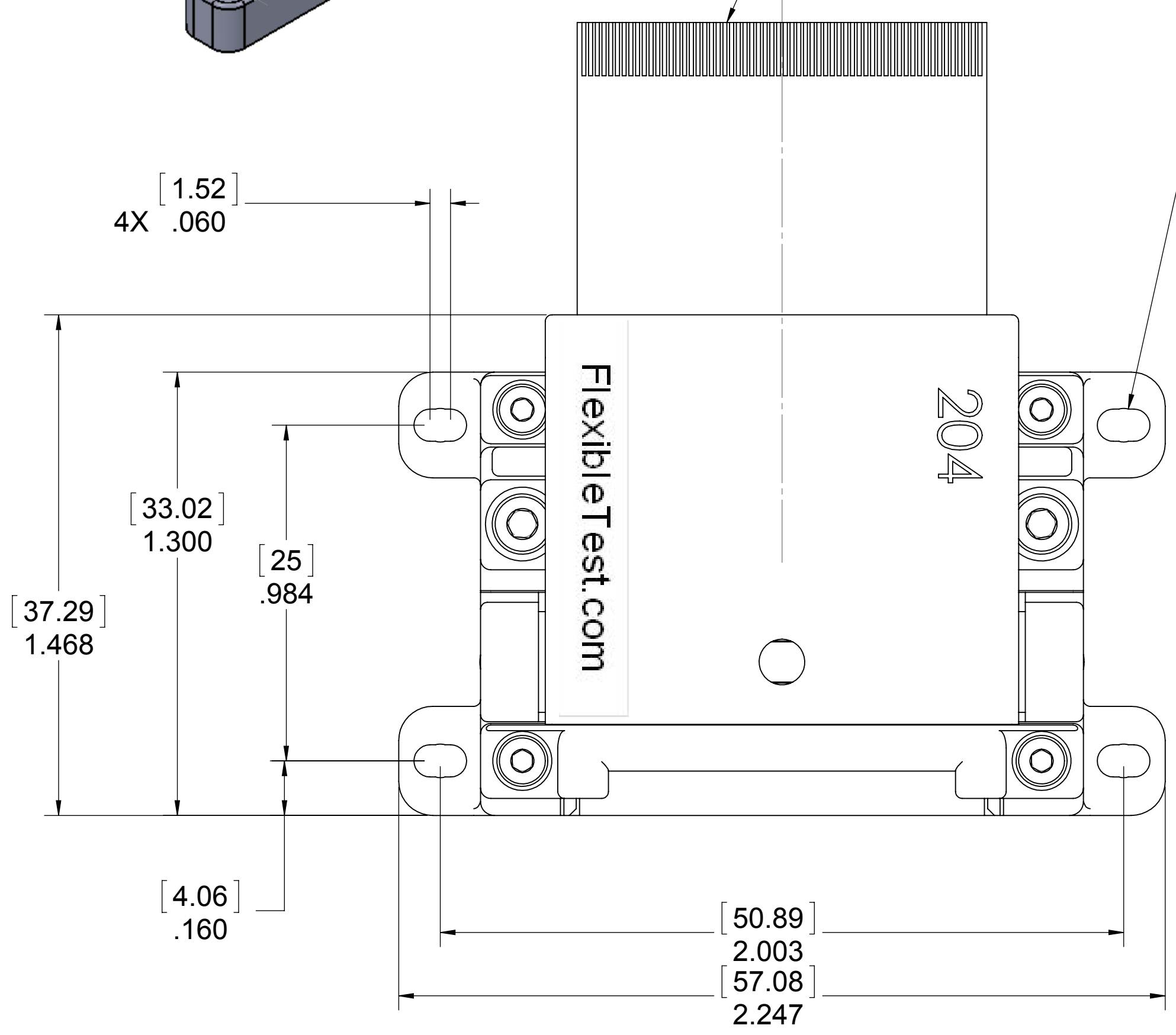

[26.88]
R1.06

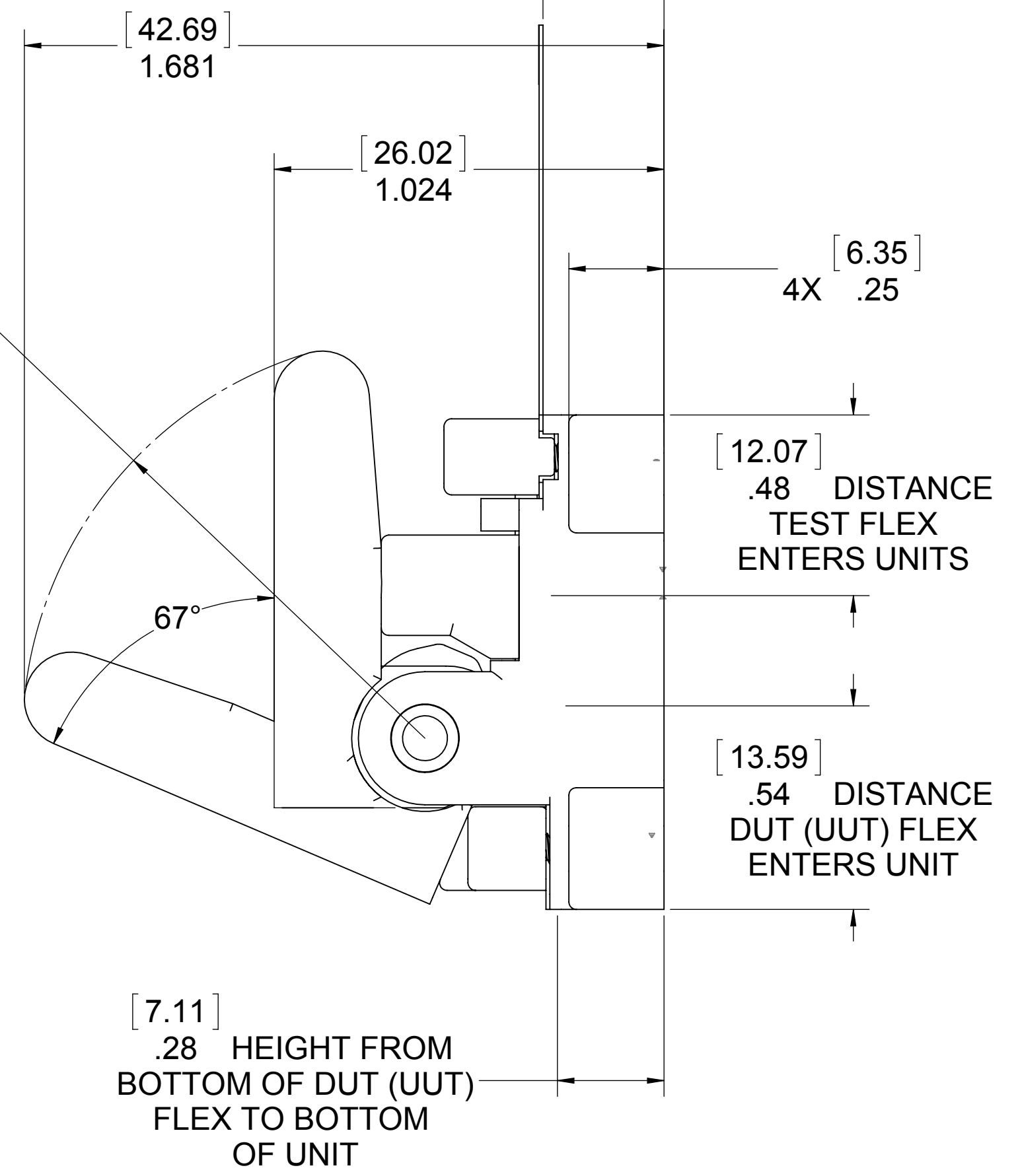

NOTE:
FOR THIS UNIT, TRACES ON DUT (UUT) FLEX MUST BE FACING UP. TRACES ON FLEX GOING OUT TO TEST EQUIPMENT ARE ALSO UP, BUT CAN FACE DOWN IF A FLIPOVER FLEX IS USED.

www.flexibletest.com

VIEWS ARE GENERATED BY THIRD ANGLE PROJECTION 	UNLESS OTHERWISE SPECIFIED: DIMENSIONS ARE IN INCHES TOLERANCES: FRACTIONAL ± 1/32 ANGULAR: MACH ± 1/2° BEND ± TWO PLACE DECIMAL ± .010 THREE PLACE DECIMAL ± .005 FOUR PLACE DECIMAL ± .0002		NAME	DATE	Z-AXIS CONNECTOR CO. TITLE: Mini Up Large FFC
	PROPRIETARY AND CONFIDENTIAL THE INFORMATION CONTAINED IN THIS DRAWING IS THE SOLE PROPERTY OF Z-AXIS CONNECTOR CO. ANY REPRODUCTION IN PART OR AS A WHOLE WITHOUT THE WRITTEN PERMISSION OF Z-AXIS CONNECTOR CO. IS PROHIBITED.	INTERPRET GEOMETRIC TOLERANCING PER: MATERIAL FINISH	DRAWN RCK 8/24/17 CHECKED ENG APPR. MFG APPR.	Q.A. COMMENTS:	
NEXT ASSY USED ON APPLICATION	DO NOT SCALE DRAWING	SHEET 1 OF 1	REV.	SHEET 1 OF 1	SHEET 1 OF 1