

| REVISIONS |      |             |      |          |
|-----------|------|-------------|------|----------|
| ZONE      | REV. | DESCRIPTION | DATE | APPROVED |
|           |      |             |      |          |

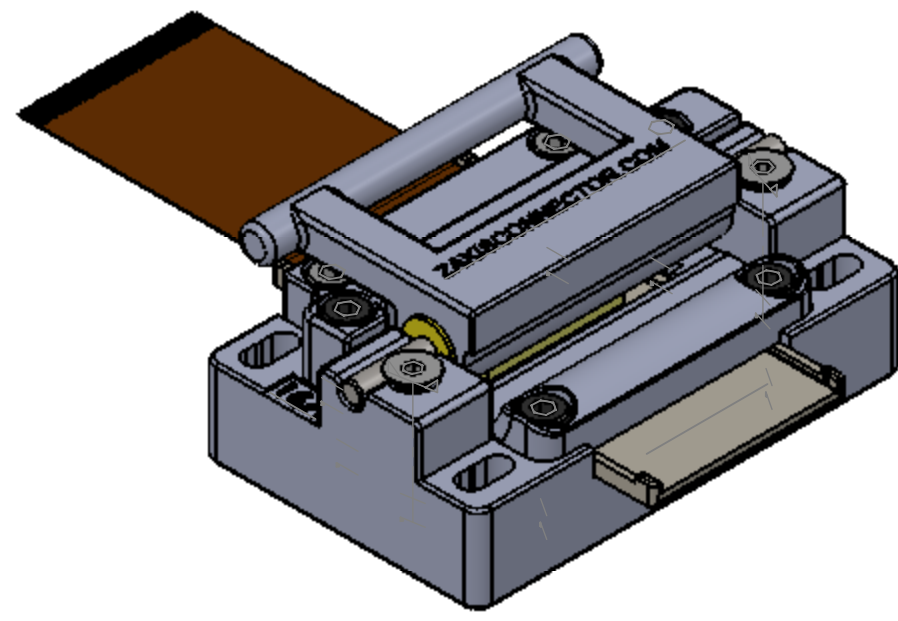

MAXIMUM FLEX WIDTH IS .5mm X 65 TRACES.  
TEST EQUIPMENT FLEX LENGTH DEPENDS  
ON AVAILABILITY.

4X CLEARANCE FOR M4  
OR 8-32 SCREWS

UNIT ID NUMBER  
TO MATCH  
ID NUMBER ON  
INSERT

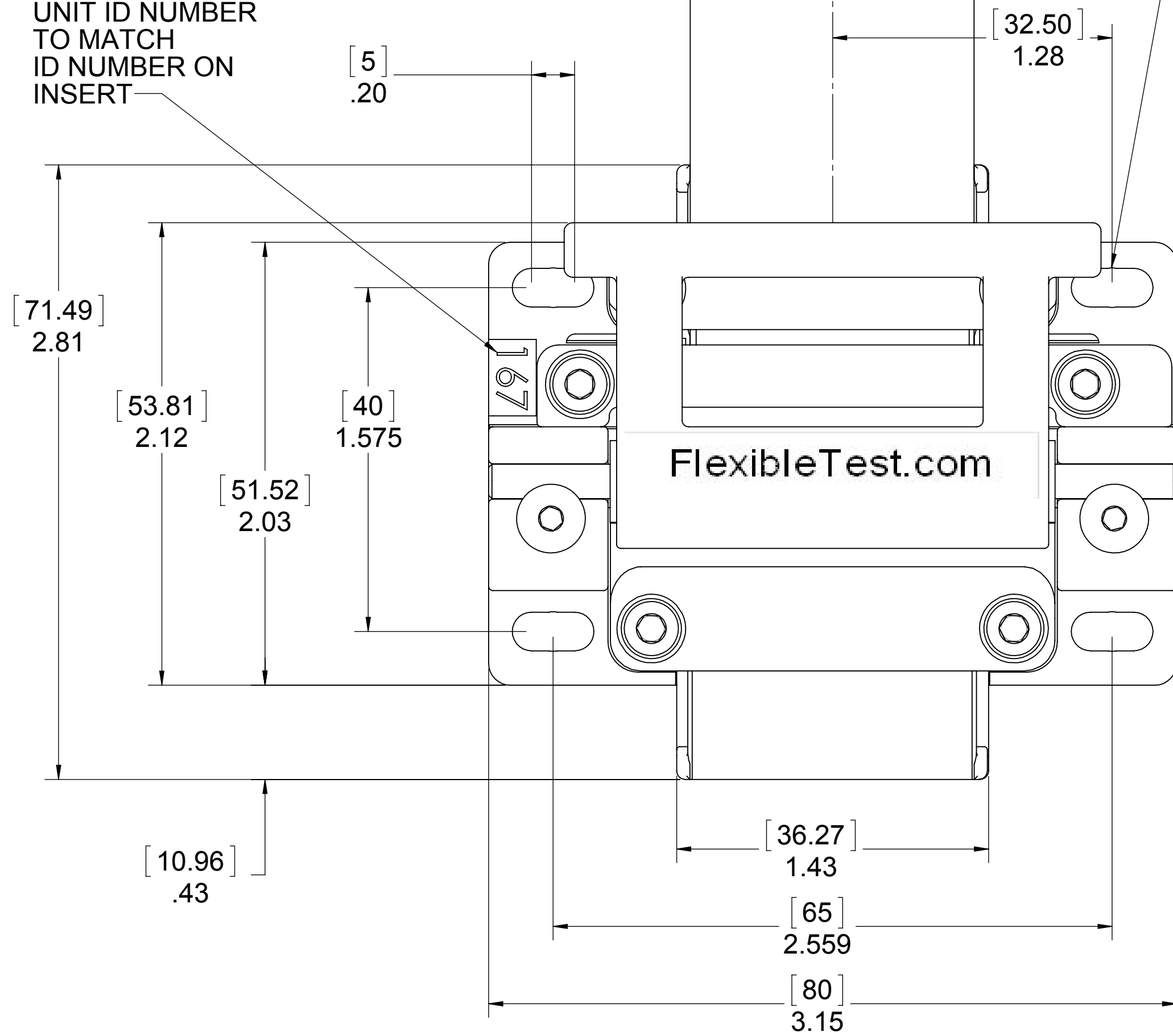

[30.78]  
R1.21

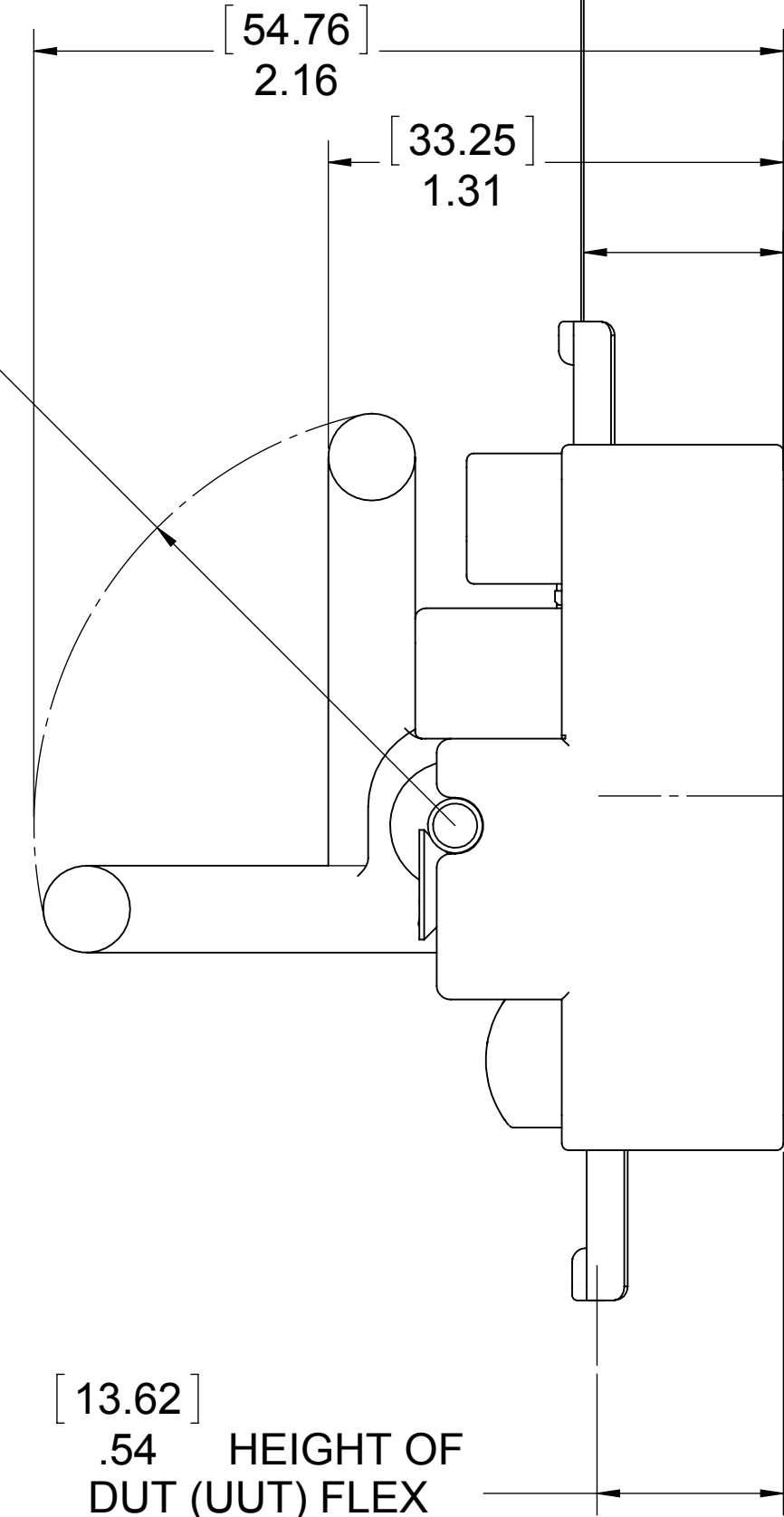

[14.58]  
.57 HEIGHT  
OF TEST FLEX  
TO BOTTOM OF  
UNIT

[25.87]  
1.02 DISTANCE  
DUT (UUT) FLEX  
ENTERS UNIT FOR  
TESTING

NOTE:  
FOR THIS UNIT, TRACES ON DUT (UUT) FLEX MUST BE FACING UP.  
TRACES ON FLEX GOING TO TEST EQUIPMENT ARE ALSO UP, BUT CAN  
BE MADE TO FACE DOWN IF A FLIPOVER FLEX IS USED.

www.flexibletest.com

VIEWS ARE GENERATED BY  
THIRD ANGLE PROJECTION

PROPRIETARY AND CONFIDENTIAL  
THE INFORMATION CONTAINED IN THIS  
DRAWING IS THE SOLE PROPERTY OF  
Z-AXIS CONNECTOR CO. ANY  
REPRODUCTION IN PART OR AS A WHOLE  
WITHOUT THE WRITTEN PERMISSION OF  
Z-AXIS CONNECTOR CO. IS PROHIBITED.

|  |             |                |
|--|-------------|----------------|
| UNLESS OTHERWISE SPECIFIED:<br>DIMENSIONS ARE IN INCHES<br>TOLERANCES:<br>FRACTIONAL ± 1/32<br>ANGULAR: MACH ± 1/2° BEND ±<br>TWO PLACE DECIMAL ± .010<br>THREE PLACE DECIMAL ± .005<br>FOUR PLACE DECIMAL ± .0002 | NAME<br>RCK | DATE<br>7/4/14 |
| INTERPRET GEOMETRIC<br>TOLERANCING PER:<br>MATERIAL  | CHECKED     |                |
| FINISH   | ENG APPR.   |                |
| APPLICATION  | MFG APPR.   |                |
| DO NOT SCALE DRAWING   | Q.A.        |                |
|  | COMMENTS:   |                |

|                                 |                        |              |
|---------------------------------|------------------------|--------------|
| Z-AXIS CONNECTOR CO.            |                        |              |
| TITLE: ORIGINAL UP<br>SMALL FFC |                        |              |
| SIZE<br>C                       | DWG. NO.<br>OUS-2D-F-A | REV          |
| SCALE: 1:1                      | WEIGHT:                | SHEET 1 OF 1 |